

Gsm Based Face Recognition using Pir Sensor on Raspberry Pi 3

G Rakesh, Padmavathi Kora, K Swaraja, K Meenakshi, G Karuna

Abstract: We Developed An Associate Approach To The Detection And Identification Of Human Faces And Describe A Operating, Near-Real-Time Face Recognition System That Tracks A Subject's Face And So Acknowledges The Person By Comparison Characteristics Of The Face To Database. Our Approach Treats Face Recognition As A Two-Dimensional Recognition Downside, Taking Advantage Of The Very Fact That Faces Area Unit Area Unit Normally Upright And Therefore Is Also Delineate By A Small Set Of 2-D Characteristic Views. Face Pictures Are Projected Onto A Feature Area ("Face Space") That Best Encodes The Variation Among Database Images. The Face Area Is Outlined By The "Eigenfaces", That Area Unit The Eigenvectors Of The Set Of Faces; They Do Not Essentially Correspond To Isolated Options Like Eyes, Ears, And Noses. The Framework Provides The Flexibility To Be Told To Acknowledge New Faces

Keywords : Raspberry pi3, PIR sensor, Face recognition, GSM Module, Embedded system

I. INTRODUCTION

Facial recognition could be a approach of recognizing somebody's face through technology. A identity verification system uses biometry to map countenance from a photograph [1], [2],[3]. It compares the knowledge with a information of renowned faces to seek out a match. Developing a procedure model of face recognition is kind of tough, as a result of faces are complicated, multidimensional, and meaning visual stimuli. They are a natural category of objects, and exchange stark distinction to undulation gratings, the "blocks world", and different artificial stimuli employed in human and pc vision research [4], [5],[6]. Therefore in contrast to most early visual functions, that we have a tendency to could construct detailed models of retinal or striate activity, face recognition may be a terribly high level task that procedure approaches will presently solely co unsel broad constraints on the corresponding neural activity. We thus targeted our analysis towards developing a kind of early, pre attentive pattern recognition capability that doesn't rely on having full three-dimensional models or careful pure mathematics. Our aim was to develop a procedure model of face

recognition that is quick, fairly straightforward, and correct in affected environments like an workplace or a social unit.

An embedded scheme be a special purpose scheme during which computer be fully encapsulated by the device or scheme it controls otherwise be devoted to it. In contrast to a universal-reason computer such as a personal computer, an embedded scheme achieves one or several pre-defined functions, generally with extremely exacting specifications. Because the scheme be devoted to exacting duties, it can be optimized by design technicians, decreasing product size and price. Mass-produced embedded systems often benefit from economies of scale.

Examples of embedded systems:

Avionics such as interial guidance systems. Flight control hardware software other embedded aircraft and missile systems

- * Cellular telephones and telephone systems
- * Automotive control units and anti-clock brake controller
- * Home automation control system such as thermostats, air conditioners, safety surveillance system
- * Handheld computer calculators
- * Handheld computer control units
- * Remote machine industrial controllers

II. METHODOLOGY

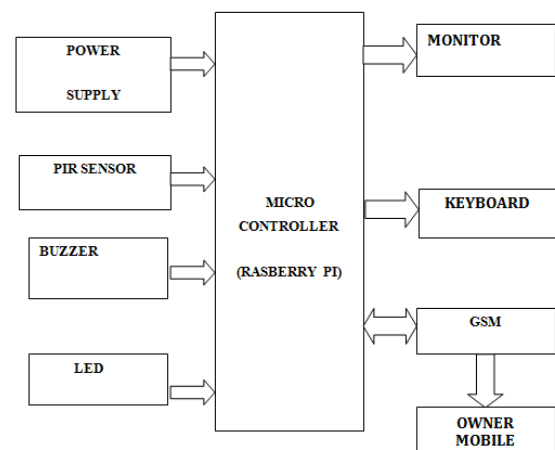

FIG. 1 Block diagram of face recognition system

2.1 BLOCK DIAGRAM DESCRIPTION

2.1.1 Power Supply

This section be projected to supply authority near every affecting beyond-declared sections. It essentially

Revised Manuscript Received on October 05, 2019.

* Correspondence Author

Gsm Based Face Recognition using Pir Sensor on Raspberry Pi 3

comprises of a transformer near step downward the 230V ac to 9V ac followed by diodes. Near remedy affecting ac to dc, diodes be worn now. Using a condenser riddle, affecting obtained rippled dc be filtered after rectification. Affecting acquired dc voltage be regulated by a favorable voltage regulator.

2.1.2 Microcontroller

This segment forms the entire project's control unit. Basically, this segment comprises of a microcontroller through its related circuitry such as Crystal through capacitors, reorganize circuitry, Pull up resistors (if required) as well as thus going on. Affecting Microcontroller shapes the core of the project as it controls the interfaced equipment plus corresponds through the machines according to affecting course organism printed.

2.2.3 GSM modem Section:

This part be made up of a modem from GSM. Utilizing sequential statement, the modem communicates with the microcontroller. Utilizing MAX 232, a sequential computer, the modem be interfaced with microcontroller. The Global Mobile Communications System be a TDMA

2.2.4 Monitor:

This chapter be essentially intended to demonstrate the project's position. This initiative uses the Liquid Crystal Display to display / invite data that be needed.

2.2.5 Buzzer Section:

These segments comprises of a Buzzer. Affecting Buzzer be used to alert / specify affecting closure of the method. It be a short times used to show affecting beginning of affecting embedded scheme through awareing through the start-up process.

2.2.6 PIR sensor:

A PIR Sensor be an electronic machine that monitors infrared (IR) noise in its area of perspective from things. PIR devices are regularly worn in affecting building of motion detectors base on PIR. Obvious movement be observed while an infrared object through one temperature, such as a person, moves in frontage of an infrared origin through another temperature, such because a partition.

2.2.7 LED:

A diode of LED be a source of light for semiconductors. LEDs be utilized in many applications as alarm lights and are increasingly used in lightning applications. Introduced as a practical digital element in 1962, old LEDs produced low-intensity blue glow, but contemporary variants are

accessible with very elevated visibility across noticeable, ultraviolet and infrared ranges.

SCHEMATIC DIAGRAM:

On the side of affecting device, affecting first, suggested plus simplest technique to power affecting Raspberry Pi be through the Micro USB port. Affecting suggested input voltage be 5V and the recommended input voltage be 2A. At Mode Pi, our normal Raspberry Pi energy supply be 5.1V@ 2.5A. The reason why the voltage be mildly increased be to negate any decrease in voltage induced by excessive present draw. This be well within Micro-USB tolerance, and from experience we have discovered that for most apps this gives the greatest stability

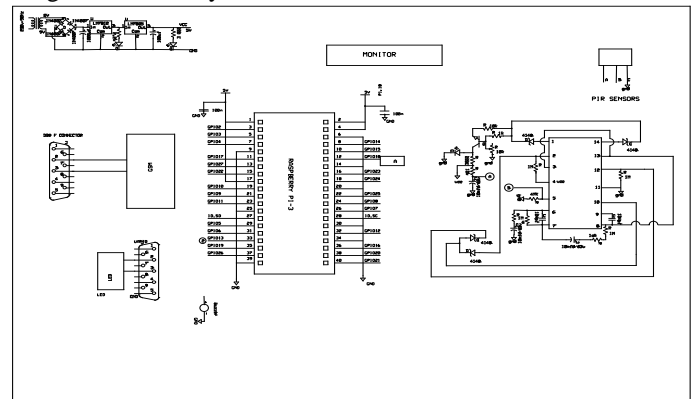

FIG. 2 Schematic diagram

RASPBERRY PI3:

Pir Sensor be conned to GPIO 21

LED be connected to GPIO 22

BUZZER be connected to GPIO 23

GSM be connected to TX-GPIO 8 and RX-GPIO 10

Affecting Raspberry Pi 2 put across multiple period plan limits as concern earlier period model. This moment epoch Raspberry Pi have a redesigned BroadcomBCM2836 workstation, which endure a ground-breaking ARM Cortex-A7 support quad-center mainframe headed within as concern facilitate remains operation at 900MHz. panel additionally comprises a development within recollection aptitude headed within errand as concern 1Gbyte



FIG 3. Raspberry pi 3 module

Product Description

The Raspberry Pi 2 delivers 6 times the processing capacity of previous models. This second generation Raspberry Pi has an upgraded BroadcomBCM2836

processor, which is a powerful ARM Cortex-A7 based quad-core processor that runs at 900MHz. The board also features an increase in memory capacity to 1Gbyte.

1) Working of the Components

In above figure 1 shows the basic block diagram of "Smart Face Recognition Security Based on Raspberry Pi". Our project system will operate in three different sections, i.e. one for capturing and creating a data base and the second section is to capture the image and which is used for identifying or comparing the images in the database and third section is to provide the intruders report to authorized user and allow him to take actions over the network. Based on the result of advance PCA algorithm and user interface, system will take appropriate action. The working of the each component is specified as follows: -

Camera module: Camera module is USB camera interface to the raspberry pi module. It is used for captures an image and send captured image to the Raspberry pi module. Raspberry pi module: Raspberry pi module is small board having the ability to act like a controller. When image provided by camera module to pi module, the raspberry pi compares it with stored face image. At the first time, we capture the image to create a data base for raspberry pi modules storage system and this data base is compared with the live captured image. After comparing two images output is considered to be positive/negative as this controller is digital; and based on the output response, it gives commands to GSM module.

GSM module: GSM module is used to sending a message to the authorities after comparing the captured image with the stored images and based on whether output is positive or negative. If

output comes out positive then "Person Identified!! DOOR OPENS!!" message send to the authority person otherwise send "unknown person is trying to unlock the door, take action". If the unauthorized person is detected then the relay will block the door. If the unknown person is known to authorized user, the user will provide a password to that person and after inserting password the door will open and will be informed to the owner. **Relay:** It will blocks the door as soon as any unauthorized person attempts to open the door.

Keypad: The keypad will allow the person to insert the password allotted to him and resets the system by unlocking the door.

Wireless signal network: This network is basically an Ethernet cable which stores the data automatically to the database and send the data to authorized user over the wireless network. Once the door gets unlocked, the system will get reset and starts from initialization.

1) WHEN THE INTRUDER IS RECOGNIZED:-

First when the session starts, it will work as follows: - the pi camera will first take the image and send it to the raspberry pi module. The raspberry pi module will then compare the captured image with the stored images in database. The advance pca algorithm comes in the action by comparing the captured image with stored images and based on this it produce the results. If the result is positive then door gets unlocked; the system informs the authorized user that known

person has got entry over the GSM module and they system gets reset.

2) WHEN INTRUDER IS NOT RECOGNIZED:-

When the result is negative, the system blocks the door and alarm starts ringing informing nearby about the unknown is trying to unlock the door. The system sends the message to the authorized user that unknown intruder is trying to unlock the door, take action and also the system sends the image of the intruder to authorized user over the wireless network. If the intruder is known to the authorized user, he will send a password to intruder and by inserting the correct password the intruder can unlock the blocked door. As soon as the door gets unlocked, the ringing alarm stops alarming and system gets reset. In this way the optimum security can be achieved over the raspberry pi module and thus allow the authorized user to interface and control in the existing scenario over the remote place.

III. APPLICATIONS: -

The " smart face recognition security based on raspberry pi" is basically based on embeded security system; the applications of this project are not limited as the each application gives rise to the new applications. so it can be implement in the following area of securities; for example,

- In car security.
- In home security.
- In budgeted industries .
- In surveillance from remote place(depending on the communication network).
- In the office cabins.
- In the shopping malls , etc.

IV. SOFTWARE USED:-

1. Linux:- as an operating system for the raspberry pi module, it will work as an working environment.
2. Python:- as an programming language, it will help the coder to create and debug the code without compiling.
3. Open cv:- as a open source computer vision it will help to capture and process the image.

V RESULTS

Raspberry Pi has enough power for HD video and image manipulation, and can be connected to the Arduino board. Connected to Raspberry Pi, Arduino can be used as a control unit while Raspberry Pi processes video images. Raspberry Pi features include Bluetooth and Wi-Fi wireless technologies and this is the shortcut to display images directly on the Android device.

Gsm Based Face Recognition using Pir Sensor on Raspberry Pi 3



FIG. 4 Images stored in data base of raspberry pi 2.



FIG. 5 Implementation of the system.



FIG. 6. Not Recognize Image

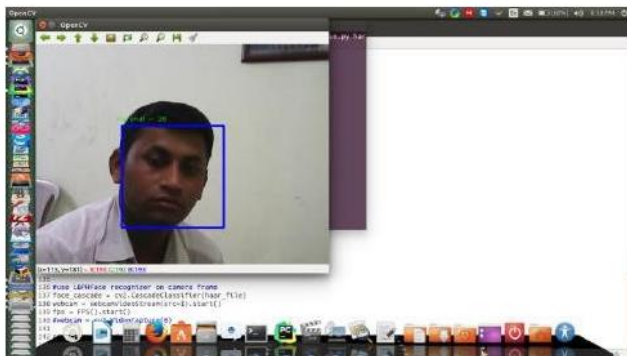

Fig.7 Recognized Image

VI CONCLUSION AND FUTURE SCOPE

A face detection system using Raspberry Pi was developed. The system was programmed using Python programming language. Both Real time face detection and face detection from specific images, i.e object recognition, was carried out. The proposed system was tested across various standard face databases such as At& T, Caltech, Indian Face Database, JAFFE, YALE B, Face94, Face95, Face96, Grimace etc with and without noise and blurring effects. The efficiency of the system was analyzed in terms of face detection rate. The analysis revealed that the present system shows excellent performance efficiency and can be used for face detection even from poor quality images. The project was intended and evaluated effectively. It was created by incorporating all the hardware parts used with

characteristics. Each module's presence was ruled out and closely positioned, thus adding to the unit's finest work. Using raspberry pi the current project can be modified by an Infrared camera interfacing it can be used in Smart Surveillance Monitoring security system which any type of public security is using Living body detection or spying, Also it can be used in Attendance system of the class, Also some profound applications can be implemented using interfacing of Raspberry pi and Arduino UNO board like sensor application of smartcard swapping, finger detection, alcohol detection, agriculture humidity sensing, Temperature sensing using web server, and many more. There are many future scopes regarding this project such as follows: -

1. If the condition improved, we can implement this system by using multimedia GSM module, in future.
2. To achieve more sound security, we can use the iris scan method.
3. To improve the system performance, we can use the advance versions of the raspberry pi module as per requirement.
4. If needed, we can make this system to be used in the air services.
5. If user needs to operate this system through android application, it is possible.

REFERENCES

1. Akshay N. Patil, Rohit B. Ranavare, Dayasagar V. Ballal: "Raspberry pi based face recognition system for door unlocking", International journal of innovative research in science and engineering vol.no.2, issue 3 march 2016.
2. SarathChanduGaddam, N. V. K. Ramesh and Hemadhanekula: "facerecognition based attendance management system with raspberry pi 2 using eigen faces algorithm", ARPN Journal of Engineering and Applied Sciences vol. 11, no. 13, July 2016 ISSN 1819-6608
3. K.ShivaPrasad: "Human Face Detection and Tracking Using Raspberry PI processor", International Journal & Magazine of Engineering, Technology, Management and Research, Volume No: 2 (2015), Issue No: 8 (August)
4. Mr.Ashwin K Kashyap, Mr.Abhishek S, Mr.Abhishek S A, Ms.Ratnakumari. C: "Face Detection using Raspberry Pi and Python", National Conference on Product Design (NCPD 2016), July 2016.
5. Liton Chandra Paul1, Abdulla Al Sumam2: "Face Recognition Using Principal Component Analysis Method", International Journal of Advanced Research in Computer Engineering & Technology (IJARCET) Volume 1, Issue 9, November 2012
6. Kora, Padmavathi. "ECG based myocardial infarction detection using hybrid firefly algorithm." *Computer methods and programs in biomedicine* 152 (2017): 141-148.